



PATTERSON PUMP COMPANY
 A Gorman-Rupp Company Phone: (706) 886-2101
 Post Office Box 790 www.pattersonpumps.com
 Toccoa, Georgia 30577 U.S.A.

CONDITION	GPM	PSI
RATED	500	100
150%	750	65

NOL (MAX) POWER

48.3 HP

3550 RPM

5x3 MAC
500 GPM
40 to 122 psi
Impeller D-5266
Catalog Curve ---

UL LISTED / FM APPROVED

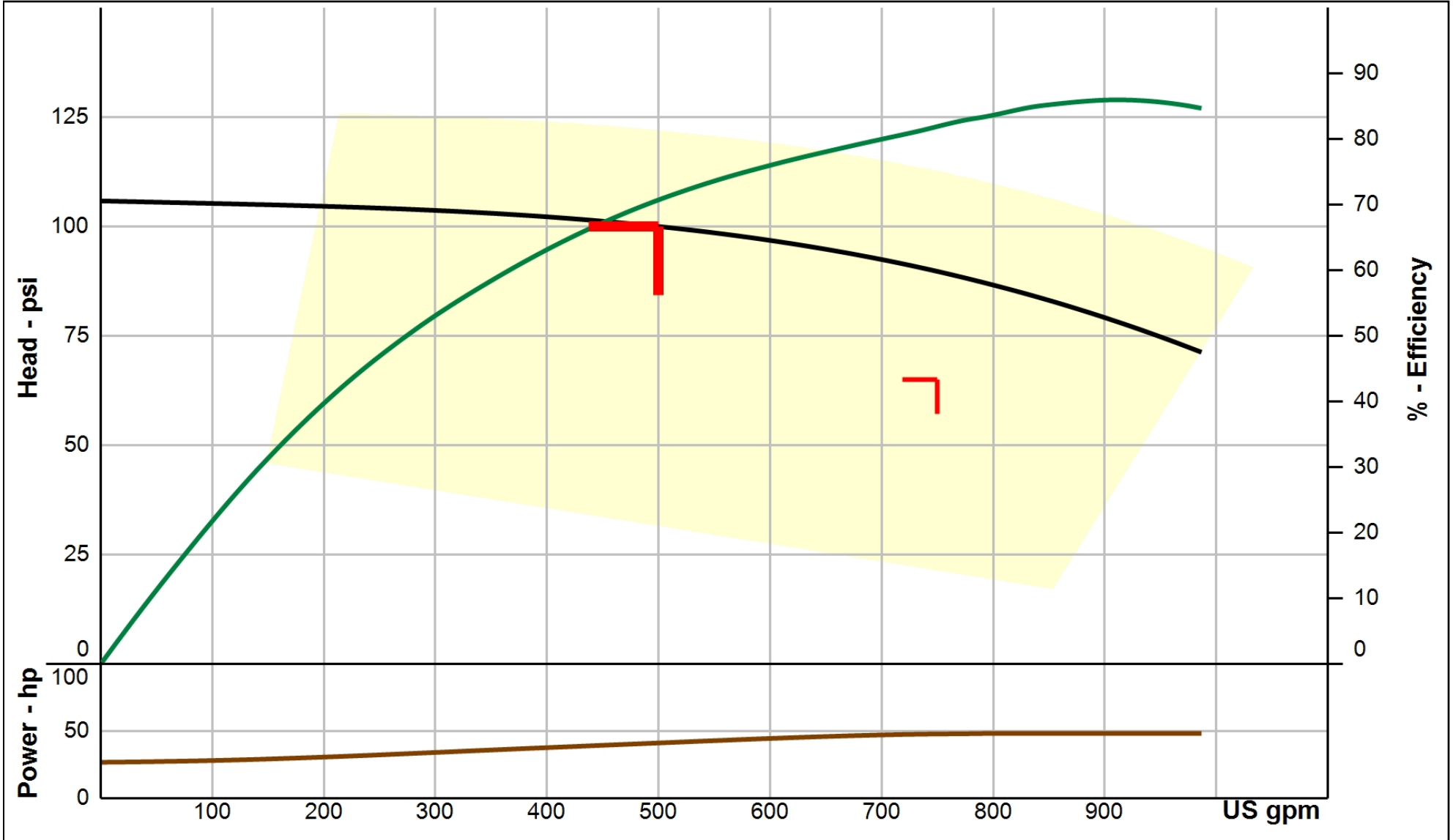

MAX SHUT-OFF PRESSURE= 112 PSI

FRESH WATER (1.0 SG)

140% RATED PRESSURE= 140 PSI

NOTE: Performance curve indicates preliminary expected performance. Actual performance is subject to ANSI/HI 14.6 Grade 1U testing tolerances. Actual impeller diameter(s), shut-off pressure, and NOL (MAX) power determined by testing. ONLY the Rated Condition (GPM & PSI) is guaranteed. Velocity head is included. Confirm all critical shut-off requirements with factory before placing an order.

PACKAGE MOUNT BASE PLATE WITH CONTROLLER AVAILABLE ON REQUEST.

UNIT:	PPC ORDER No:				
JOB:	CUSTOMER PO No:				
PUMP:	5x3MAC	CAPACITY:	GPM@:	FT. HD.	
MOTOR:	HP	PHASE	MAKE:	VOLT	R.P.M.
CONTROLLER:	CYCLE				
CERTIFIED BY:	DATE:				

- NOTES:
- 1) CLOCKWISE ROTATION SHOWN WHEN VIEWED FROM THE DRIVER END. SUCTION IS ON THE RIGHT, DISCHARGE IS ON THE LEFT. FOR COUNTERCLOCKWISE ROTATION, SUCTION IS ON LEFT, DISCHARGE IS ON RIGHT. WHEN VIEWED FROM DRIVER END.
 - 2) GROUT HOLES ARE PROVIDED.
 - 3) IMPORTANT; BASEPLATES MUST BE GROUTED TO THEIR FULL DEPTH.
 - 4) ALL DIMENSIONS ARE ± 1/4" / 6.4mm (EXCEPT FOR FLANGE DRILLINGS).
 - 5) MOTOR WEIGHT AND DIMENSIONS MAY VARY BY MANUFACTURER AND FRAME TYPE. DIMENSIONS AND WEIGHT DEPICTED ARE FOR LARGER ODP MOTOR OF OPTIONS LISTED ON DRAWING.

APPROX. WEIGHTS:	
MOTOR WT MAY VARY - SEE NOTE 5	
PUMP =	320 LBS / 145 KG
MOTOR =	328 LBS / 239 KG
CPLG. =	12 LBS / 5 KG
GUARD =	18 LBS / 8 KG
BASE =	268 LBS / 122 KG
TOTAL =	1146 LBS / 520 KG

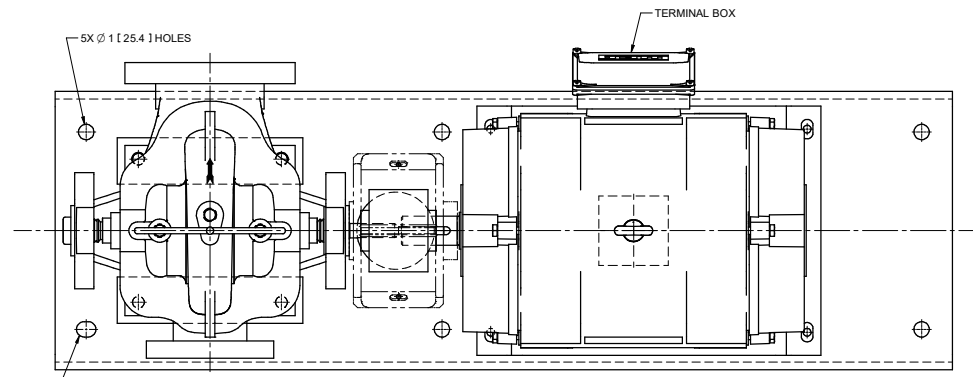
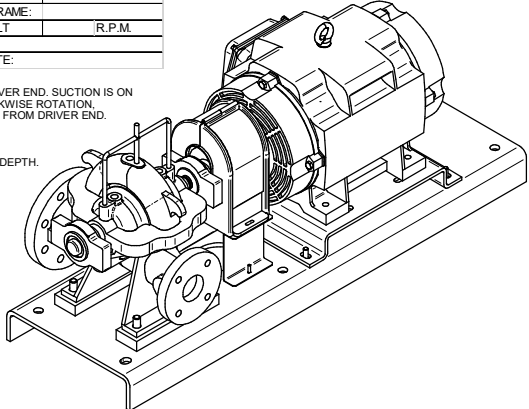

PLAN VIEW

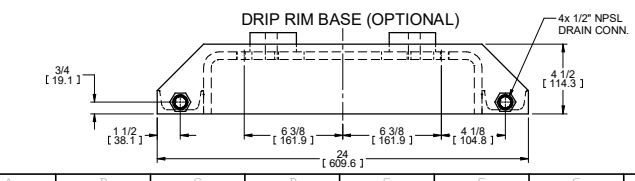
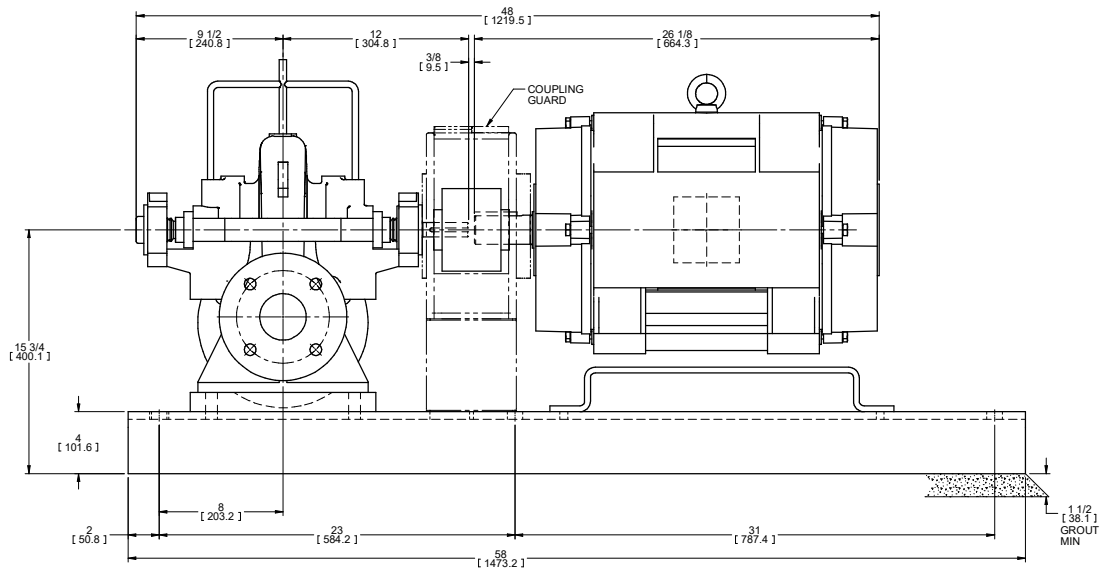
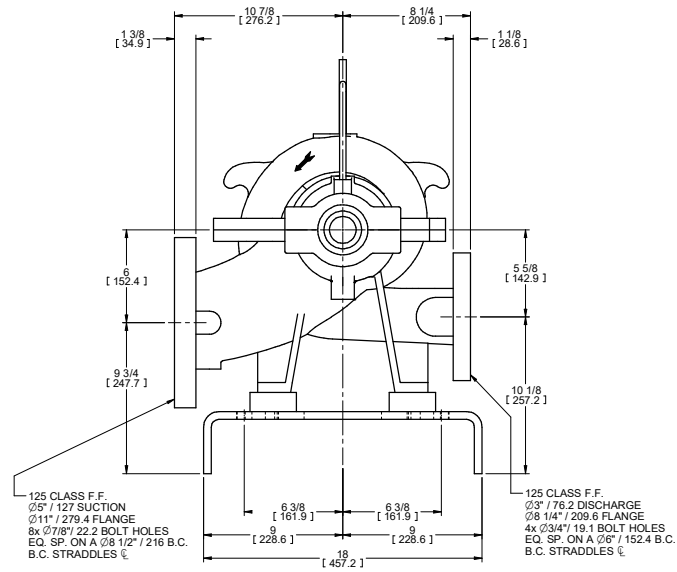

DIMENSIONS IN () ARE FOR REFERENCE ONLY ALL PRIMARY DIMENSIONS ARE IN INCHES AND SECONDARY DIMENSIONS, SHOWN IN [], ARE IN MILLIMETERS

<p>PATTERSON PUMP COMPANY A GORMAN-RUPP COMPANY</p>	<p>OUTLINE DIMENSIONS 5 X 3 MAC SPLIT CASE PUMP WITH 324TS / 326TS ODP MOTOR</p>		<p>DWG. NO. D02-153082</p>	<p>REV. 0</p>
	<p>SCALE 1/4"=1"</p>	<p>APPROV. BG</p>	<p>DATE 11/14/2019</p>	<p>SHEET OF 1 1</p>
	<p>DRAWN tammijordan</p>	<p>DATE 11/14/2019</p>		

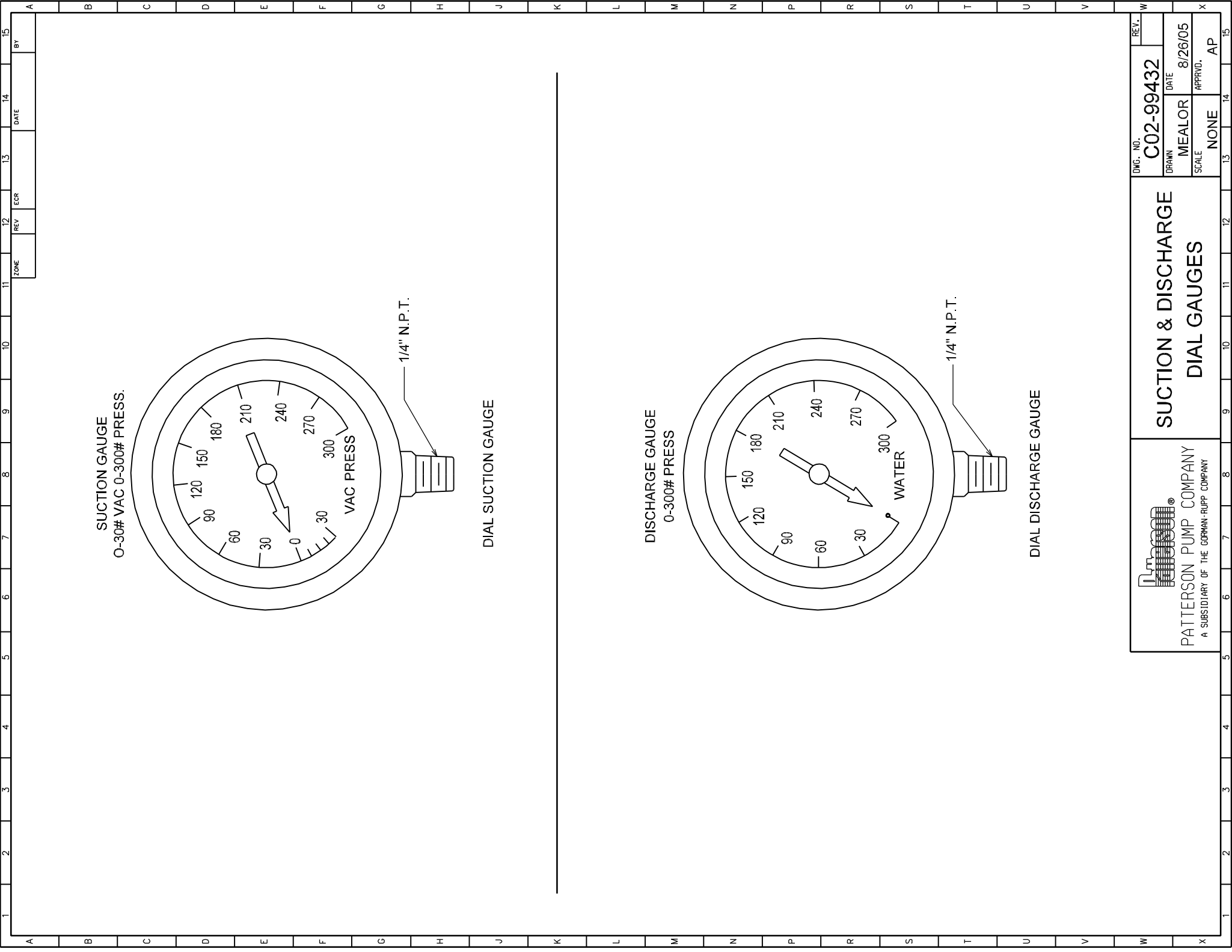

SUCTION GAUGE
O-30# VAC 0-300# PRESS.

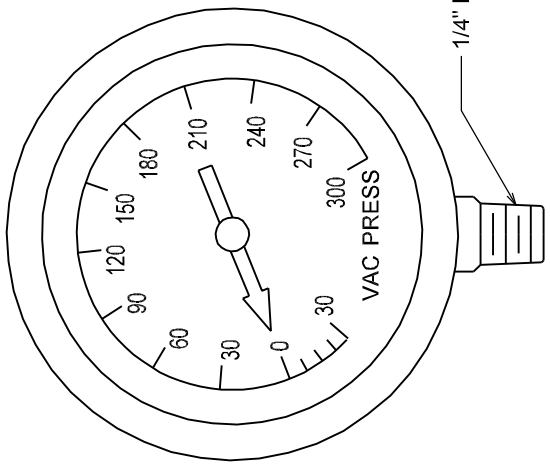

DIAL SUCTION GAUGE

DISCHARGE GAUGE
O-300# PRESS

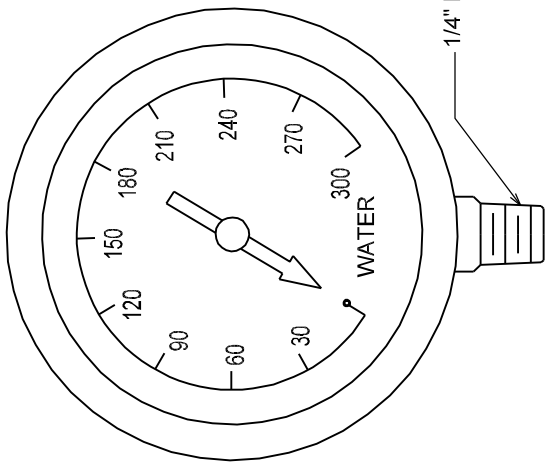

DIAL DISCHARGE GAUGE

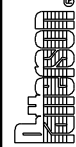

PATTERSON PUMP COMPANY
A SUBSIDIARY OF THE GERMAN-RUPP COMPANY

**SUCTION & DISCHARGE
DIAL GAUGES**

DWG. NO.	C02-99432	REV.	W
DRAWN	MEALOR	DATE	8/26/05
SCALE	NONE	APPRVD.	AP